



Research and Analysis of Aviation Cable Comprehensive Testing System

Peipei Ren

AVIC Xi'an Aircraft Industrial Corporation Co., Ltd., Xi'an 710000, Shaanxi, China.

How to cite this paper: Peipei Ren. (2025). Research and Analysis of Aviation Cable Comprehensive Testing System, *Aerospace and Aeronautical Engineering*, 1(1), 5-8. DOI: 10.26855/aae.2025.07.002

Received: May 23, 2025

Accepted: May 26, 2025

Published: July 24, 2025

***Corresponding author:** Peipei Ren, AVIC Xi'an Aircraft Industrial Corporation Co., Ltd., Xi'an 710000, Shaanxi, China.

Abstract

In recent years, various industries have accelerated their development speed and pace, and the aviation industry in China is also doing the same. Aviation cables are very important in the aviation industry and are one of the most important "roles" in ensuring normal aviation activities. During the flight of an aircraft, aviation cables can orderly transmit information and provide electrical energy. If there are problems with aviation cables, it is impossible for the aircraft to fly smoothly and normally. Therefore, this article mainly conducts a careful analysis of the aviation cable comprehensive testing system, hoping to play a role in helping China's aviation industry achieve better development and other aspects.

Keywords

Aviation cable; Comprehensive; Testing; System; Research

As time goes by, my country's economic strength is rapidly improving. Aviation manufacturing companies are keeping up with the pace of the times and developing and moving in a better direction. At the same time, this situation also shows that my country's aviation industry has achieved better development, become stronger, and has stronger capabilities. Aviation cable is a very important component of aviation electrical appliances, and is closely related to whether the aircraft can fly smoothly. Under the background of the new era, many requirements are put forward for aviation cables, and aviation electrical appliances need to develop in the direction of intelligence and multi-function. Based on this, this article mainly discusses the comprehensive test system of aviation cables.

1. Overview

As we all know, the "aircraft engine" is called the heart of the aircraft. The aviation cable is set on the aircraft engine to provide help and support for the stable and safe operation of the aircraft. It is understood that the traditional method of cable testing is manual testing, which has many problems, such as: the method lacks scientificity and reliability. Nowadays, there is no way to meet the requirements put forward in the modern production process. For this reason, a more reliable and efficient automated testing professional equipment is needed, so the aviation cable automatic test system came into being and appeared in front of people.

Through the study of the cable automatic test system, it is found that this system is mainly based on the principle of testing and clear process performance requirements, and uses modern detection technology and computer technology to design a more advanced test system to truly achieve the goal of automatic detection. The biggest feature is that the operation is not complicated, and the test results presented are more accurate and real. The biggest feature is that it does not put forward more and higher requirements for the operator. The staff only needs to have a small amount of computer operation knowledge to better operate the cable automatic test system. Figure 1 is a schematic diagram of the cable test system structure block diagram.

2. Impact of Cable Failure

In order to ensure that the aircraft is safer and flies more smoothly during the operation, it is necessary to carry out aviation cable detection. Manual detection, cable program control detection, cable microprocessing and automatic

detection are the more common and frequently used aviation cable detection technologies and methods nowadays. Different detection methods will present very different characteristics. Many detection methods play an important role in ensuring the orderly transmission of aircraft power and stable signal transmission.

Among aviation electrical appliances, aviation cables are very important components, which play the role of connection and signal transmission and have a close relationship with the normal operation of aircraft. If there is a problem during the operation, the electrical system of the aircraft will no longer function or even be paralyzed. It is extremely difficult for an aircraft to fly safely and smoothly, and it may even increase the possibility of accidents. In 2002, a certain aircraft of a certain airline in my country had aviation cable failures many times. Therefore, many requirements are put forward for cables during the flight of the aircraft. Figure 2 is a schematic diagram of aviation cables.

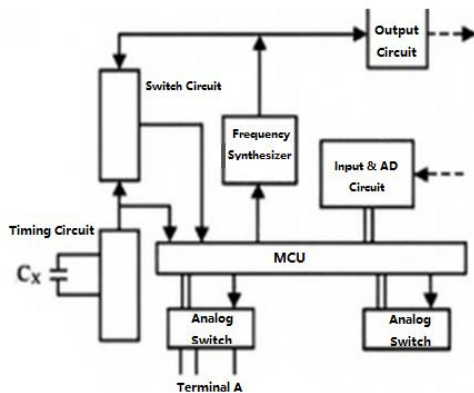

Figure 1. Schematic diagram of cable test system structure.

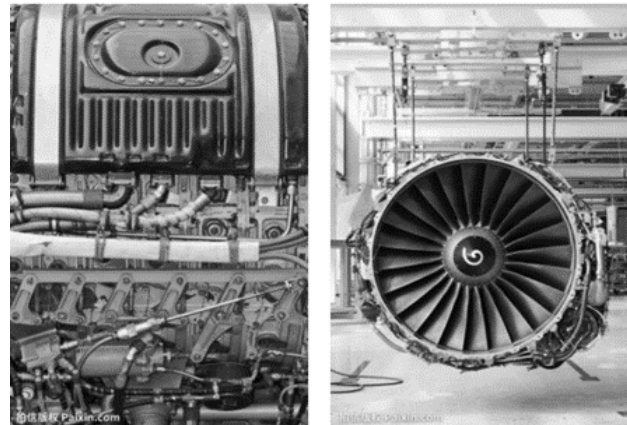

Figure 2. Schematic diagram of aviation cable.

3. Aviation Cable Failure

3.1 Aircraft adverse conditions

The aircraft structure itself is very complex. During the application process, the cable is easily affected by various factors and various problems occur, such as: accelerated aging. First: high internal temperature. Under the influence of high temperature, the insulation aging speed of the cable will inevitably accelerate, increasing the possibility of short circuit problems. Second: high internal current. Because the current is too high, the operating temperature of the equipment will also be affected, and there will be an upward trend, which will eventually lead to the cable being unable to be used normally. Third: It is easy to have temperature accumulation problems. The temperature inside continues to rise, so the specific use time of the cable is shortened. Fourth: The internal environment space is very small. In a limited space, the arrangement of the cable is affected and compressed. With the continuous passage of time, the cable slowly breaks.

3.2 Thermal aging phenomenon

First of all, no matter what kind of electrical equipment is used for a long time, thermal aging problems will occur. What is thermal aging phenomenon? It mainly refers to the influence of heat on the cable for a long time, so the external insulation medium has chemical problems and the insulation performance continues to decline. Once the thermal aging problem occurs, it will inevitably have different degrees of impact on the operation of the aircraft, and even lead to safety problems. Therefore, the staff needs to regularly maintain and replace the cables that have been used for a long time.

3.3 Mechanical aging problem

What is the mechanical aging problem? It is mainly caused by the influence of the external environment on the electrical equipment, deformation, and external insulation, which will cause damage. Once the damage problem occurs, the insulation of the insulating parts will inevitably be affected and the problem of decline will occur. Therefore, during the actual operation of the equipment, it is necessary to prevent the influence of external factors and reduce the possibility of mechanical aging problems.

3.4 Electrical aging problem

Through a careful analysis of the electrical aging problem, it is found that the causes are diverse, and the most important factor is that the equipment is affected by the electromagnetic field for a long time, so the use time is shortened.

4. Main Principles of the Cable Automatic Test System

It is understood that the domestic aviation cable detection technology is not very advanced and has backward problems. Compared with the aviation electrical detection technology of developed countries abroad, there is still a certain distance, so it is very important to increase efforts to develop my country's cable detection technology. Most of my country's aviation cable detection work will use traditional methods. The biggest problem with manual detection is slow operation and low detection efficiency. This situation will definitely have a lot of impact on the better development of the aircraft manufacturing industry.

4.1 Test bus unit

In the cable automatic test system, the test bus unit is a very important component. On the circuit board, the power supply unit, conduction unit, relay unit, etc. are all connected together through the test bus. Each functional unit cooperates to finally complete the cable test. The test bus will transmit the relevant information setting signal between the computer interface unit and each functional test unit.

4.2 Conductivity test unit

Through a careful analysis of the interface circuit inside the conduction unit, it is found that the test line on the test bus is switched according to the received control signal, mainly switching to the test circuit. At this time, after the circuit completes the test work, the result will be transmitted to the computer through the test bus.

4.3 Relay matrix unit

The cable test system is mainly based on computer-controlled relays to truly achieve the switching goal of contacts and test instruments. By switching the contact selection relay, the two cable contacts are switched to the test line, and the other contacts are disconnected. By switching the function selection relay, the two test lines are connected to the corresponding test instrument, and the relevant test work is successfully completed.

4.4 Overall test process

Through the analysis of the overall test process, it is found that it mainly includes: test start, then enter the cable drawing number to be tested, and then connect the cable to be tested according to the prompts, test, print and save.

5. Solutions to Aviation Cable Fault Problems

5.1 Careful study of cable fault mechanism

If you want to better solve the aviation cable fault problem, the first thing you need to do is to carefully study and analyze the cable fault mechanism, find the rules in the fault machine, and provide help for solving the aviation cable fault problem. In addition, you need to enter the experimental process, according to scientific simulation analysis, deepen the insulation aging experiment, and finally find the fault cable conditions that are prone to occur during the operation stage of the aviation cable system, laying the foundation for the development of fault prevention work.

5.2 Application of fault testing technology

Under normal circumstances, state maintenance technology is diverse, including multiple aspects, such as: state prediction, state evaluation, etc. What is equipment operation prediction? It is mainly through the known and understood operating status, analyzing various factors in climate and operation, and then increasing the intensity of operating status prediction, relying on the autoregressive model, and using a pre-emptive method to grasp the aviation cable fault.

5.3 Online fault diagnosis

It is understood that fault diagnosis plays an irreplaceable role. However, it is undeniable that because there is no rule for the fault, once a cable fault occurs, it cannot be solved in the first time. Therefore, it is also necessary to identify faults according to online fault detection methods and use backup equipment. The application process of fault detection technology needs to be strengthened. If a fault occurs, the problem can be solved by intelligent methods.

6. Future Development Direction and Trend of Aviation Cable Detection Technology

Any technology needs to be constantly updated during its development. Only in this way can it meet the requirements of social development. The same is true for aviation cable detection technology. The main direction in the future is to follow program control and take program control as the basis to truly achieve the goal of automatic detection and greatly improve the level of detection technology. Nowadays, in the process of cable detection, the program equipment used is a detection state with test software, which is fully connected to the computer. The two cooperate to detect aviation cables. MPT-5000 cable detector, MNTS bus test equipment, etc. are the most valued and widely used detection equipment. These equipment can truly achieve the goal of improving the detection level. The MPT-5000 cable detection instrument has 1500 detection points and a very short detection time. If the manual inspection method is still used, the inspection task will be very large, but by using the MPT-5000 cable tester, the work level and efficiency can be further improved.

In addition, when the program controls the cable inspection, the relevant steps must be strictly followed, and there must be no problems such as illegal operations. Otherwise, the inspection activities cannot be carried out with high quality.

7. Conclusion

In short, the speed and pace of development of my country's aviation industry has accelerated, and professional aviation electrical appliances have added momentum to the better development of the aviation industry. Nowadays, aviation electrical appliances are developing and advancing in the direction of high precision. Among aviation electrical appliances, aviation cables play a major "role". If there is a problem with the aviation cable, it is impossible for the aircraft to fly more smoothly, and it may even increase the possibility of accidents. Therefore, relevant staff need to carefully inspect the aviation cables that have been used for a long time, promptly discover the problems and faults in them, and finally formulate scientific methods to effectively solve the problems, ensure that the aviation cables have no quality problems, and ensure a smoother flight of the aircraft. In the context of the new era, many new processes, new materials, and new equipment have appeared in front of people. Professional staff in aviation enterprises have finally designed a cable brake test system through continuous research. This system plays an important role in improving the level of domestic equipment design and manufacturing. After a lot of practice, it is found that this system fully meets the requirements put forward in production work.

References

- [1] Li SS. Universal test system for high-voltage insulation resistance of aviation cables. *Anhui Sci Technol.* 2022;(9):50-1.
- [2] Huang MJ, Lü ZZ, Li CX. Research on aviation cable detection technology and application practice. *Equip Manag Maint.* 2022;(10):123-5.
- [3] Gao S, Cai J, Li HL. ADC frequency increase method of aviation cable fault detection equipment. *Meas Control Technol.* 2021;40(9):71-6,89.
- [4] He YH, Yang B, Zhang Z, Zhang JP, Cui RH. Ignition performance and smoke characteristics of aviation cables under low-voltage environment. *Sci Technol Eng.* 2021;21(6):2545-9.
- [5] Wang Z, Zou JY, Qu F. Analysis of the influence of aviation cable arrangement on combustion characteristics. *Eng Technol Res.* 2021;6(4):28-9.
- [6] Wang J. A brief discussion on the design of automatic test system for aviation complete cable. *Enterp Technol Dev.* 2016;35(2):6-7.
- [7] Li PH, Lin H. Design of automatic test system for aviation complete cable. *Comput Meas Control.* 2010;18(4):789-91.
- [8] Zhang ZT, Guo X, Li H, Wang JT. Research on automatic test system of a new type of aviation engine cable. *China New Technol Prod.* 2012;(14):3.
- [9] Chen Y, Zhao ZP. Research on distribution machine of aviation cable test system based on CAN bus. *Mod Electron Technol.* 2011;34(6):25-7.